

**HYUNDAI**  
POWER PRODUCTS

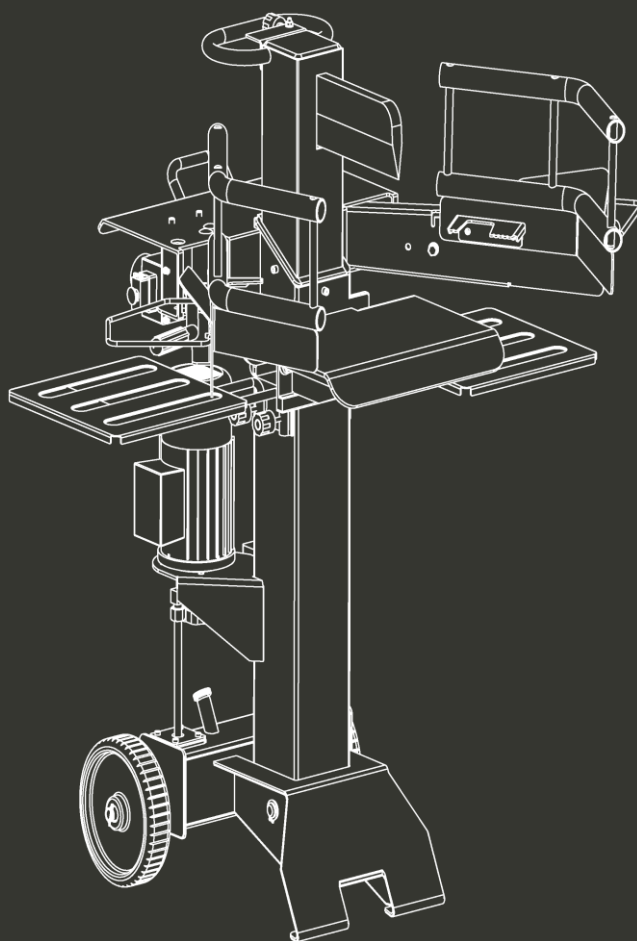







# **ELECTRIC LOG SPLITTER**

## **HFBE8T55**

**ORIGINAL INSTRUCTIONS**



**WARNING:** Read thoroughly the instruction manual before use.

	Read manual before operation
	Use safety footwear
	Use work gloves
	Wear face protection
	Use hearing protection
	No trespassing
	No smoking in the working area
	Only the operator may stand within the operating range of the machine. Keep non-involved persons, as well as domestic and farm animals, out of the hazard area (minimum distance: 5m)
	Keep your work space tidy! Untidiness can lead to accidents
	Only the operator may stand within the operating range of the machine.

**For your safety.**

**Read and understand the entire manual before operating the machine.**

**Save This Manual for Future Reference.**

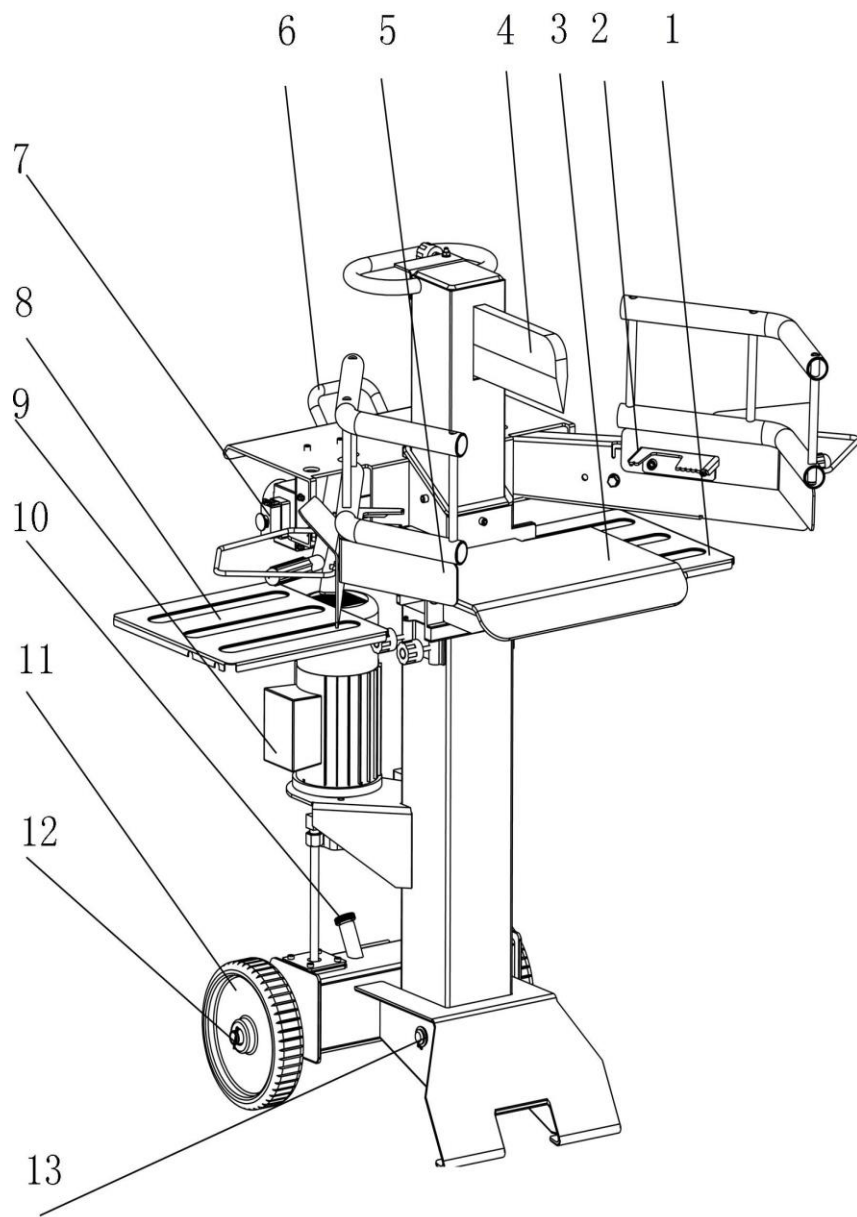

- 1. right storage;
- 2. right support;
- 3. working table;
- 4. splitting wedge;
- 5. left handle guard;
- 6. transport handle;
- 7. switch KOA7;
- 8. left log support;
- 9. motor (3kw/230v/50hz)
- 10. oil dipstick;
- 11. wheel;
- 12. axle;
- 13. connedting shaft.

## Technical data

Technical data		
Engine		Electrical motor
Input power(P1)	kW	3.0
Voltage	V	230V~/50Hz
Motor speed	Min <sup>-1</sup>	2800
Operating mode		S6/40%
Splitting force	ton	8
Weight	kg	112
Cutting length	mm	550
Size of log	mm	70-400
IP number		IP54
Hydraulic pressure	MPa	24
Sound power level	dB	91

## Hydraulic diagram

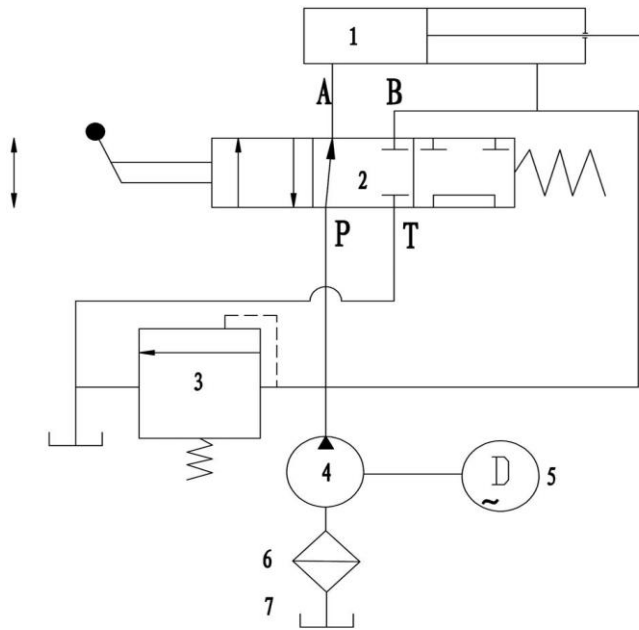

## Wiring diagram

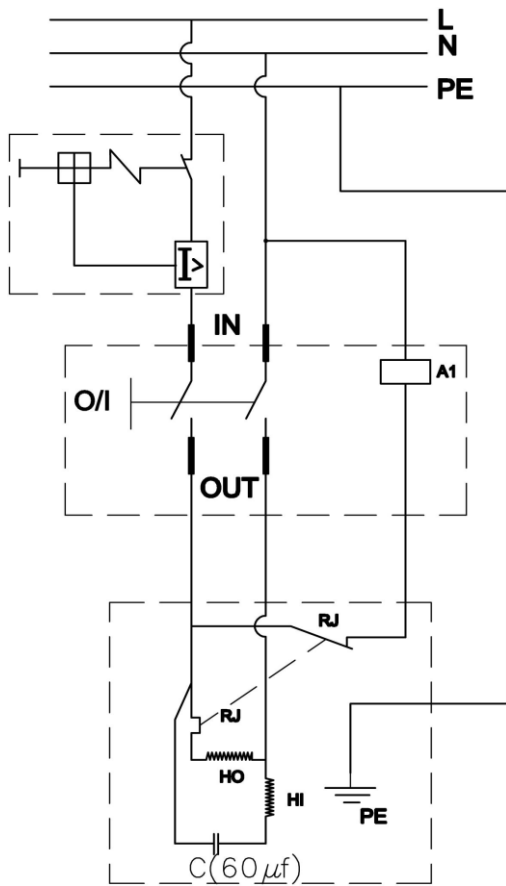

# Exploding view

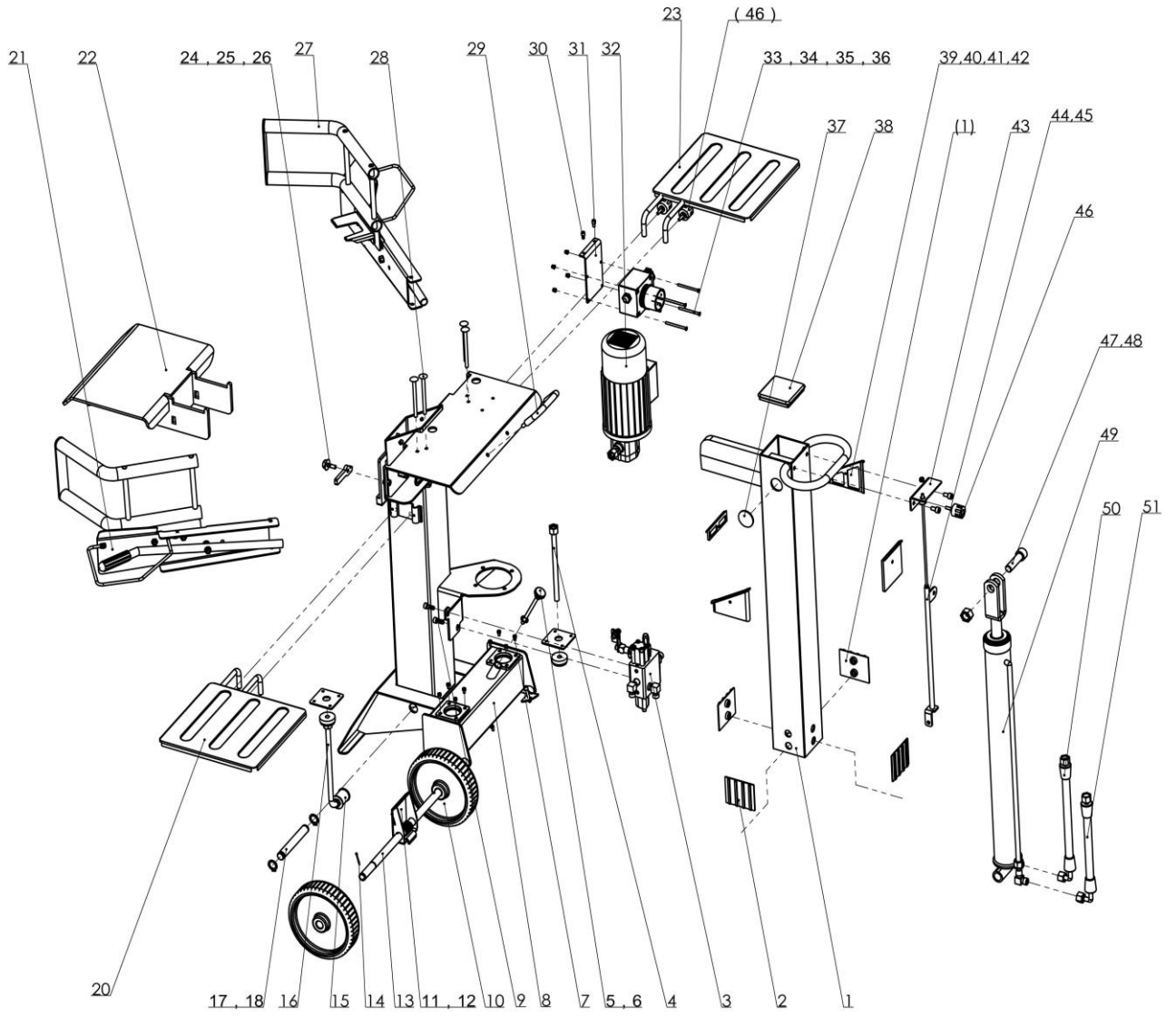

## SAFETY WARNINGS

### Keep these instructions for future reference

1. The log splitter must always be used by one operator only.
2. Nobody must be allowed to use the log splitter unless they have read the instruction manual and have been instructed in the regulations to follow for correct and safe use. Operators must receive necessary training and instructions.
3. The machine must be used by adults only. Use of the log splitter by apprentices of not less than 16 years of age must be supervised by an adult authorized to use the machine.
4. Never wear loose, unbuttoned clothing which may become trapped in moving parts.
5. Check that the logs to be split are free from nails or wire, which may fly up or damage the machine, the ends of the logs must be cut square, branches must be cut off flush with the trunk.
6. Never try to split logs larger than those indicated in the technical specifications. This could be dangerous and may damage the machine.
7. Break wood in the direction of the grain, do not place wood across the log splitter and leave it in that position for splitting; it may be dangerous and may seriously damage the machine.
8. Never attempt to cut two logs at once, one may fly up and hit you.
9. If the log moves away from the blade, retract the blade and turn the log through 90°.
10. Do not attempt to load the log in the log splitter while the blade is in motion, you could get trapped and injured.
11. Keep your hands well away from any splits and cracks which open in the log; these may close suddenly and crush or amputate your fingers.
12. Never force the log splitter for more than 5 seconds keeping the cylinder under pressure in the attempt to split excessively hard wood. After this time interval, the oil under pressure is overheated and the machine could be damaged. It is thus better to stop and rotate the log by 90° to see whether it can be split in a different position. In any case, if you are not able to split the log, this means that its hardness exceeds the capacity of the machine and thus that log should be discarded so as not to damage the log splitter.
13. Do not force the blade by pushing the log on the upper part, as this can cause the blade to break or damage the body of the machine. Always set the log on the guides.
14. Never leave the machine unattended while it is running. If you leave the machine, even for a short time, remove the power supply or any possible cause of accidental start-up.
15. The log splitter must never be used by an operator who is under the influence of alcohol, drugs, medicines, or who is tired. A clear mind is essential for safety.
16. Never request the assistance of another person to help you remove a jammed log.
17. Do not use machines with electric motor if natural gas, petrol fumes or other inflammable vapors are present.
18. Check that the electric circuit is adequately protected and that it corresponds with the power, voltage and frequency of the motor, check that there is a ground connection, and a regulation differential switch upstream.
19. Check on the functioning of the machine.
20. Never open the switch box on the motor. Should this be necessary, contact a qualified electrician.
21. Make sure that the machine and the cable never come in contact with water.
22. Treat the power cable with care, do not attempt to move the machine by pulling the cable, do not yank the cable to unplug it; keep the cable away from excessive heat, oil and sharp objects.
23. Never leave the machine unattended with the power supply "on", also disconnect the power cable when not in use, when carrying out maintenance work, when changing attachment or moving the machine.
24. Before starting work, hydraulic pipes and hoses shall be inspected and the stopping devices shall be tested.



25. Stop the machine before cleaning or making adjustments.
26. The hazards may arise from particular characteristics of wood when being split (e.g. knots, logs of irregular shape etc.).
27. Operator must receive necessary training and instruction from a qualified person before handling the tool.
28. Use the tool only for the intended use. Misuse (such using material other than log) can damage the tool and cause accidents and injuries.
29. The splitting operation of the machine is designed to be activated by one person. While there is the possibility that additional operators could be working with the machine (e.g. for loading and unloading), only one operator should activate splitting operations;
30. The machine shall not be used by children
31. Wear suitable personal protective equipment (PPE), including safety footwear close fitting clothing and suitable work gloves, eye protection and hearing protection.
32. Tests of the machine's safety devices before use the tool. If safety devices do not work properly, do not use the tool and bring it to a qualified technician for inspection and repair.
33. The working area shall be free from obstructions; before installation and operation, clear the working area. Keep the working area free from obstructions, e.g. logs, split wood, etc.
34. Do not reach into the splitting zone.

## Electrical Safety

**WARNING!** Always check that the power supply corresponds to the voltage on the rating plate.  
**WARNING! Connect the main leads to a standard 230V±10% (50Hz±1Hz) electrical supply which has protection devices of under-voltage, over-voltage, over-current as well as a residual current device (RCD) which maximum residual current rated at 30mA.**

## Replacing cables or plugs

If the supply cord is damaged, it must be replaced by the manufacturer, its service agent or similarly qualified persons in order to avoid a hazard.

Immediately throw away old cables or plugs when they have been replaced by new ones. It is dangerous to insert the plug of a loose cable in the wall outlet.

## Using extension cables

1. As a supply for this machine always use an unloaded line and/or extension with conductor of at least 2.5mm<sup>2</sup> and protected with a 20A fuse. Be sure that this extension cable is no longer than 10 meters. Excessively long cables or inadequate section can cause voltage drops that prevent motor from developing its full power.
2. Only connect your machine and/or extension cable to earthed electricity mains.

## Grounding

In the event of an electrical short circuit, grounding reduces the risk of electric shock. Use switch socket with grounding please.

## INTENDED USE

This log splitter is only intended to be used to split logs! Serious injury may occur if this log splitter is used for any other purpose.

## RESIDUAL RISKS

The machine is built according to the current state of technology and generally recognized safety standards. However, individual residual risks may occur when working with the machine.

Risk of injury to fingers and hands from the cleaver, in the event of improper guidance or support of the wood.

Risk of injury from the ejection of the work piece, in the event of inappropriate support or guide.

Exposure to electric current, when using inappropriate electric connecting cables.

Furthermore, unapparent risks may remain, despite of all the measures taken.

Residual risks can be minimized, if the safety instructions, the proper use and the operating instructions are observed.

## **TRANSPORT INSTRUCTIONS**

Transport by hand, Fig. 1

To transport the log splitter, completely retract the cleaver blade

1. Slightly incline the splitter on the cleaver column, using the handle until the machine tilts on to the wheels and thus can be moved.

Transport by crane:

Never lift by the cleaver blade!

Storage conditions:

Observe the following conditions during storage:

Dry, indoor location

Max. Humidity 80 %

Temperature range - 20 °C to +60 °C

Only operate the machine under the following ambient conditions:

	minimum	maximum	recommended
Temperature	5 C°	40 C°	16 C°
Humidity		95 %	70 %

## **FREEING A JAMMED LOG**

- Release both controls.
- After the log pusher moves back and completely stops at its starting position, insert a wedge wood under the jammed log.
- Start the log splitter to push the wedge wood to go completely under the jammed one.
- Repeat above procedure with sharper slope wedge woods until the log is completely freed.

## **SET UP**

Prepare the location where the machine is to be installed. Provide sufficient space to ensure safe, trouble-free working conditions.

Carefully remove all pieces from the carton. Place the log splitter on a flat, high work surface so that the control actuators are between 850 mm and 1650 mm high from the ground (recommended height: 880mm).

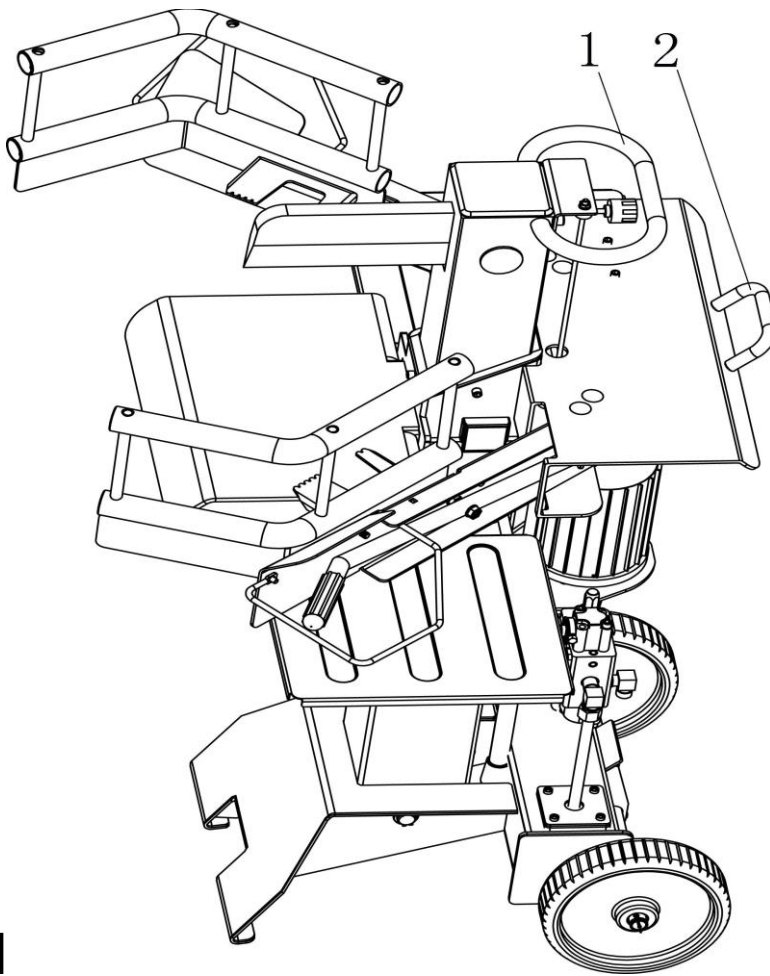

Fig.1

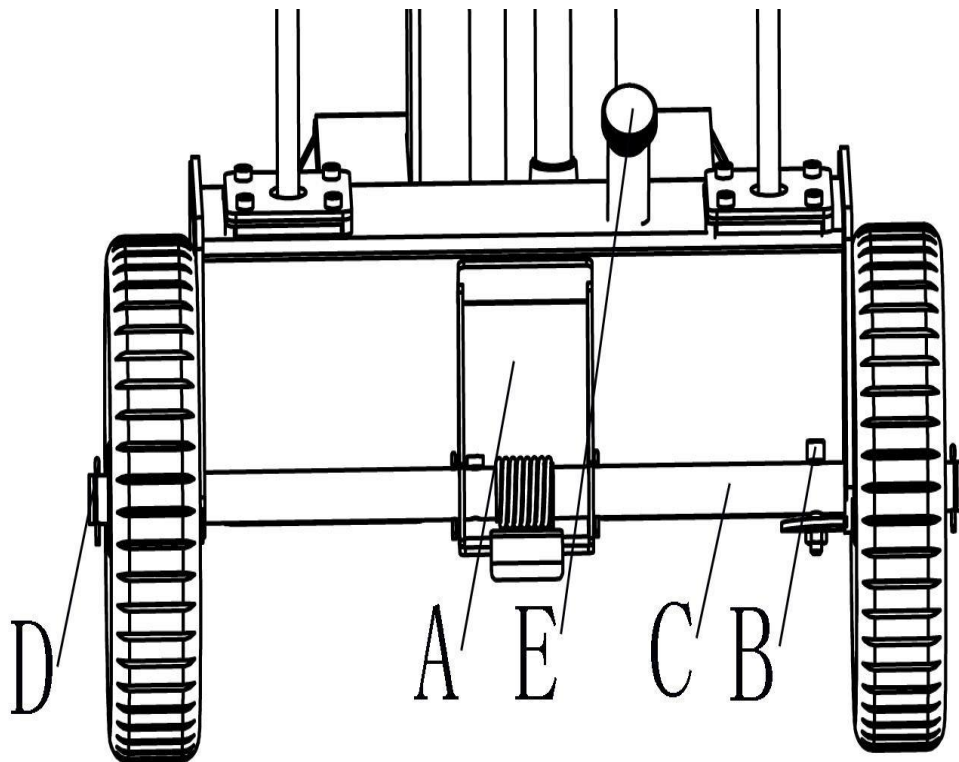

Fig.2

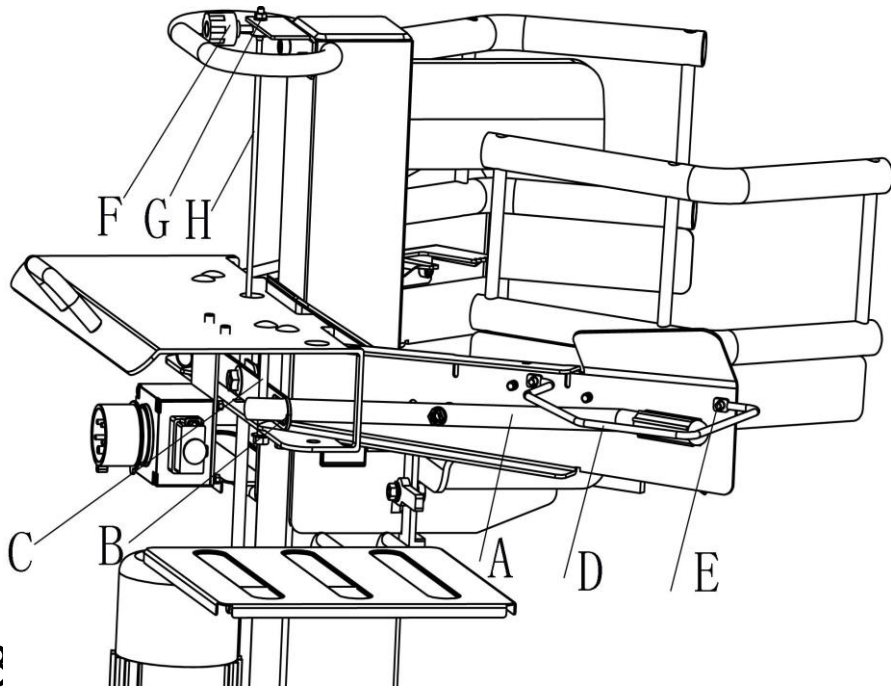

Fig.3

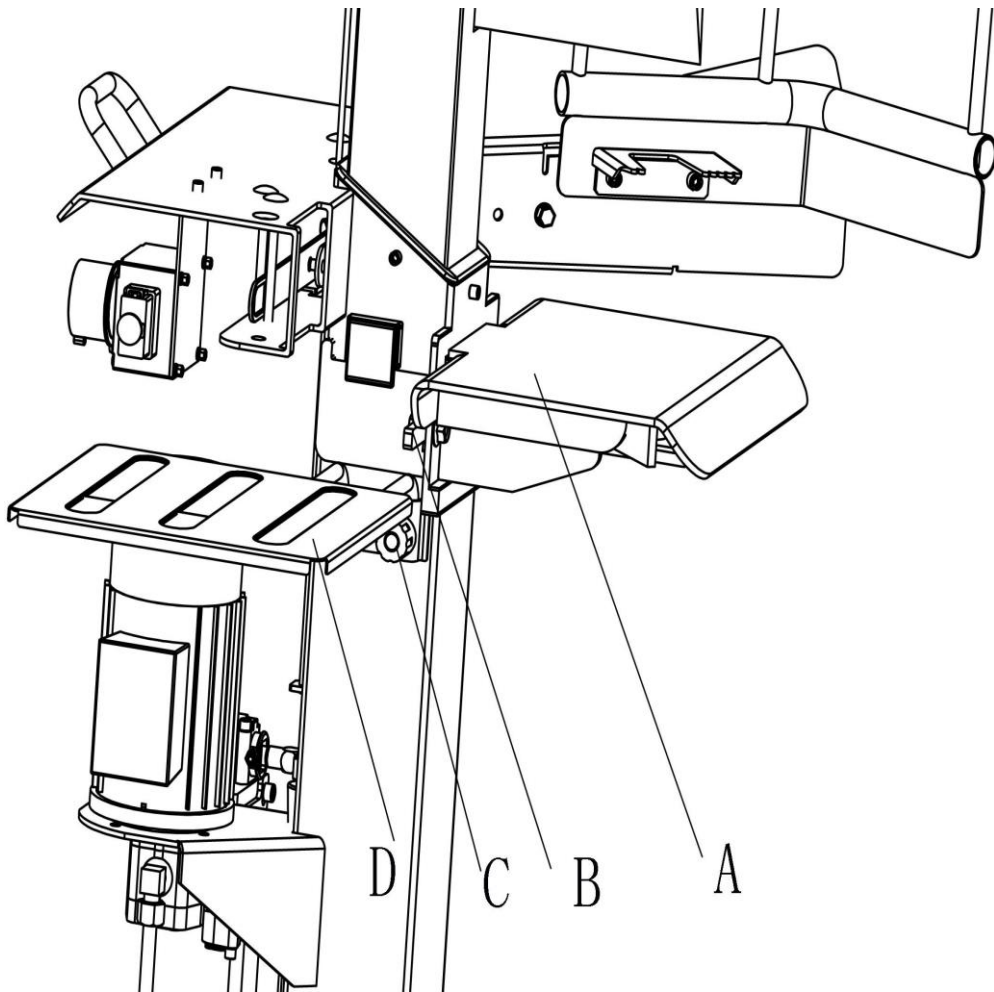
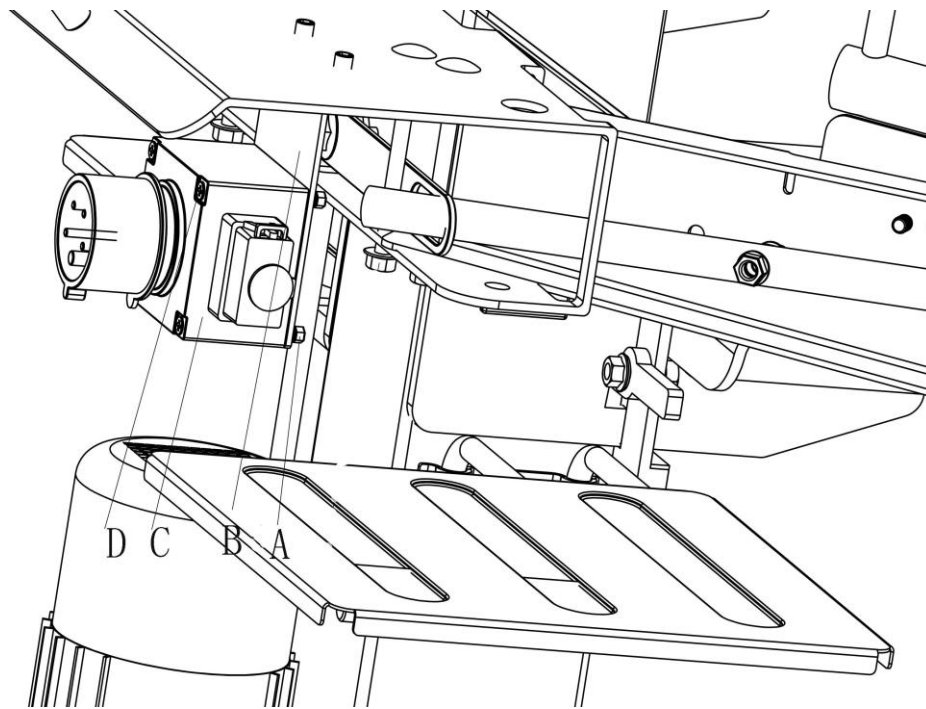

Fig.4



**Fig.5**

## ASSEMBLY

For packing reasons, your wood log splitter is not completely assembled.

### Mounting the wheels, Fig .2

Insert the wheel axle with pedal (A) through the two holes on the oil tank.

Insert the hexagon socket screw M6 (B) through the wheel axle and tighten it onto the lug (C) with a safety nut.

Then, mount a wheel on each side and secure both with a cotter pin (D). Slightly bend the cotter pin to prevent it from falling out.

### Mounting the control arms, Fig.3

Insert the control arm (A) in the rocker switch (B), and screw it in place with the hexagon bolt (C), the washer and the safety nut. Tighten the lock nut so the control arm can still be moved.

Now, mount the control arm on the right, following the method described above.

Mount the hoop guards (D) to both control arms, using 2 crosshead screws (E) in each case. For reference, according the following steps:

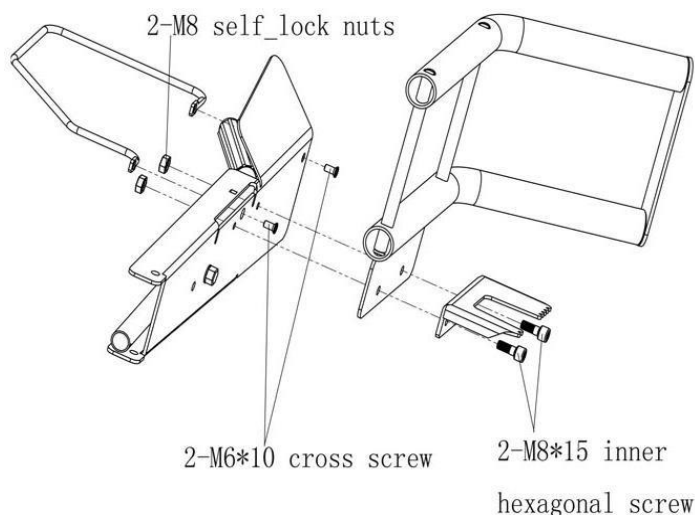

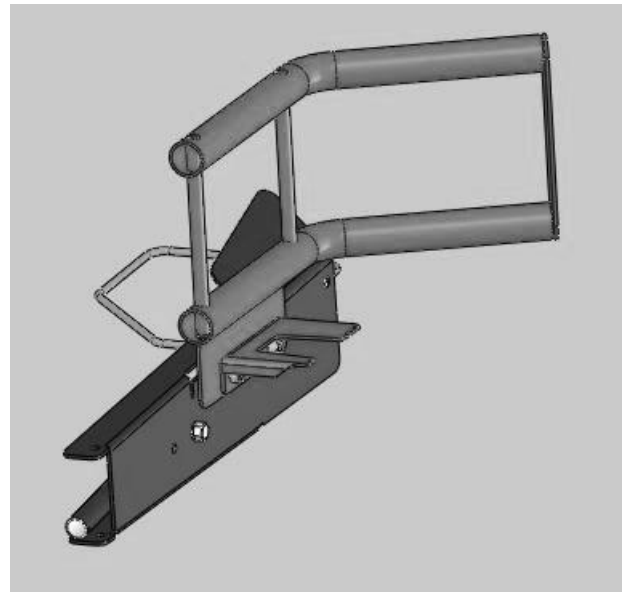
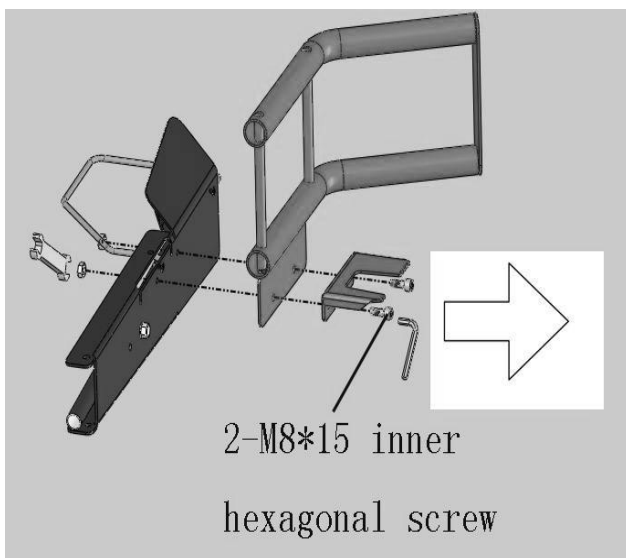
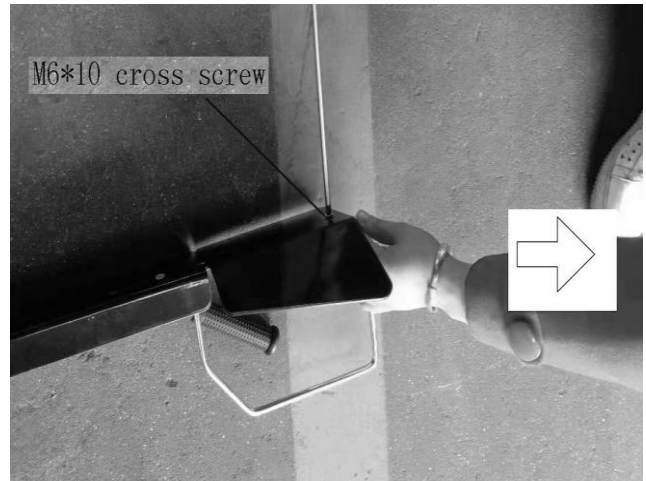
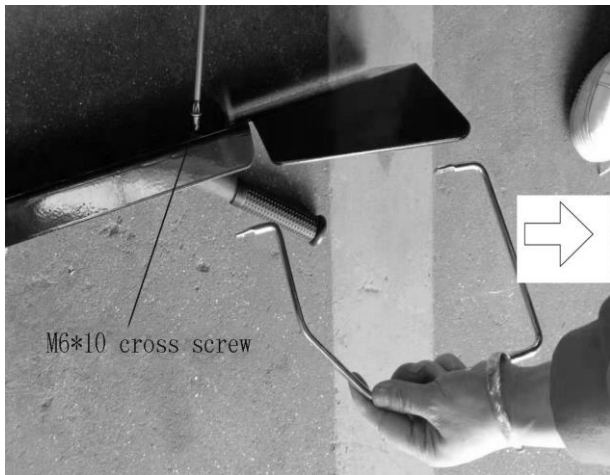

#### Mounting the left/right storage Fig .4

Insert the left storage(D) through the two holes on the main body column, and lock it with two M6 Knobs (C). With the same way to mount the right storage.

For reference, according following steps:

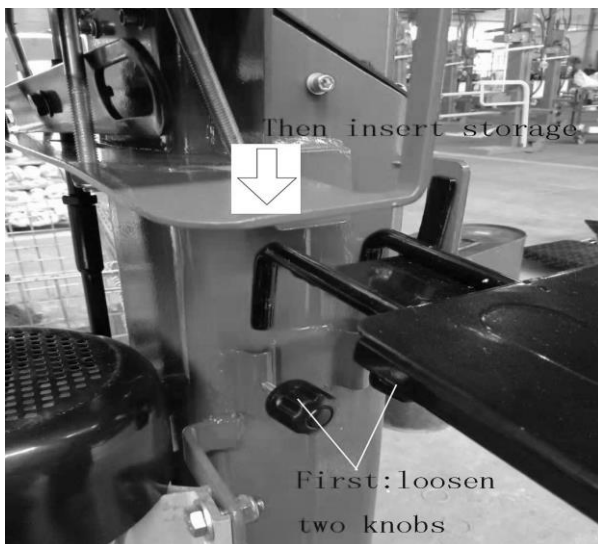



### Mounting the table, Fig. 4

Depending on the length of the timber to be cleaved, the Table(A) can be mounted at 1 height: 55 cm. Locking levers (B) are available at installation position. Now, secure the table with the locking lever on both sides.



### Mounting the switch, Fig.5

Mount the switch (C) to the board(B), and fix it with 4-M4\*60 cross cap bolt(D), the washer and 4-M4 nuts.

### Functional test

A functional test must be performed prior to each use.

Press both handles down. Cleaver blade goes down - to approx. 10 cm above the table. Release one handle at a time Cleaver blade remains in the selected position.

Release both handles simultaneously; Cleaver blade runs back to the upper position.

Check the oil level before each use, see chapter "Maintenance"

### Splitting

Place the log on the log splitter table, hold the log firmly with the two control handles, press both operating handles down simultaneously, once the cleaver blade penetrates into the log, push the handles outward with simultaneous pressure downward. This prevents pressure from being exerted on the retaining plates.

Only cleave logs that are sawed straight off.

Cleave the log vertically.

Never split horizontally or crosswise.

Wear safety gloves when cleaving the logs.

### Efficient operation

Upper position approx. 5 cm above the log

Lower position approx. 10 cm above the log

### Start-up

Ensure that the machine is assembled completely and correctly. Before each use, check:  
 The connecting cables for defects (splits, cuts, etc.),  
 The machine for any damage,  
 That all screws are tight,  
 For any possible leaks in the hydraulic system and the oil level  
 Guard: hydraulic hose and soft hose.

### Venting, Fig. 7

Bleed the hydraulic system, before you put the log splitter into operation.  
 Loosen the dipstick (E) by a few turns, so that air can escape from the oil tank.  
 Leave the cap open during operation.  
 Close the cap again, before moving the splitter, otherwise oil may leak.  
 If the hydraulic system is not vented, the trapped air will damage the seals and thus the splitter!

Fig. 6

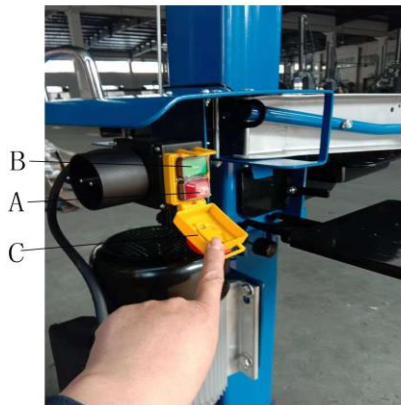
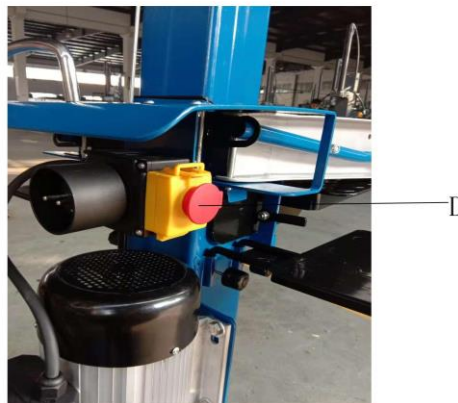

Fig. 7



### Switch on/off - Fig. 6/ 7

Open the protective cap (C).  
 Press the green button (A) to switch the appliance on. Press the red button (B) to switch the appliance off. Press the emergency stop (D) in the event of emergencies.  
 Note: Prior to each use, check the functioning of the on off switch by switching the device on and off. Restart protection in case of power failure (No-voltage release switch)  
 The equipment will switch off automatically in the event of a power failure, accidental removal of the plug or if a fuse is triggered. Press the green button on the switch unit to restart the machine.

### Finishing work

Bring the cleaver blade to the lower position.  
 Release one of the control arms.  
 Switch the machine off and disconnect the power.  
 Tighten the bleed screw.  
 Follow the general maintenance instructions.



### **Electrical connection**

Check the electrical connecting cables regularly for any damage. When checking the connecting cables, make sure that they are not connected to the mains.

Electrical connecting cables must comply with the relevant VDE and DIN regulations.

Only use connecting cables labeled H 07 RN.

It is mandatory that the type designation be printed on the connecting cable.

Use a portable safety switch (PRCD), if a residual-current- operated protective device (RCD) with a nominal residual current of max. 0.03 A is not provided in the supply network.

### **Defective electric connecting cables**

Connecting cables often suffer insulation damage. The causes are:

Pressure marks, when the connecting cables are led through windows or door gaps.

Kinks, due to improper mounting or leading of the connecting cables.

Cuts from crossing the connecting cables.

Insulation damage, from pulling the cables out of the wall socket.

Cracks due to the aging of the insulation.

Such defective electric connecting cables must not be used and are dangerous to life because of the damaged insulation!

Single -phase motor 230 V / 50 Hz Mains voltage 230 V / 50 Hz

The mains connection and the extension cables must be 3-wire=P+N+SL.(L/N/PE).

The extension cables must have a minimum cross section of 1.5mm<sup>2</sup> and must not exceed a length of 20 m. The mains connection is fused for a maximum of 16 A.

### **MAINTENANCE AND REPAIR**

Only carry out conversion, adjustment and cleaning work when the machine is switched off.

Disconnect the appliance.

Skilled mechanics may carry out small repairs on the machine.

Repair and maintenance work on the electrical system may only be carried out by qualified electricians.

All protective and safety devices must be immediately replaced after repair and maintenance work.

Clean the machine thoroughly after each use!

### **Cleaver blade**

The cleaver blade is a wearing part that should be reground or replaced with a new blade, as required.

### **Two-hand guard**

The combined clamping and control device must remain.

Smooth running. Lubricate occasionally with a few drops of oil.

### **Moving parts**

Keep the cleaver blade guides clean. (Dirt, wood chips, barks, etc.)

Lubricate the slide rails with oil spray or lubricating grease

Check the hydraulic oil level.

Check hydraulic fittings and connections for leaks and wear. If necessary, tighten the bolted connections.

Fig. 8

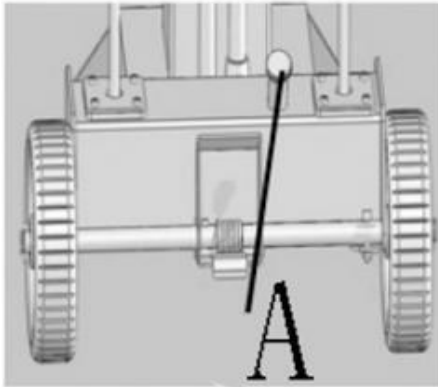
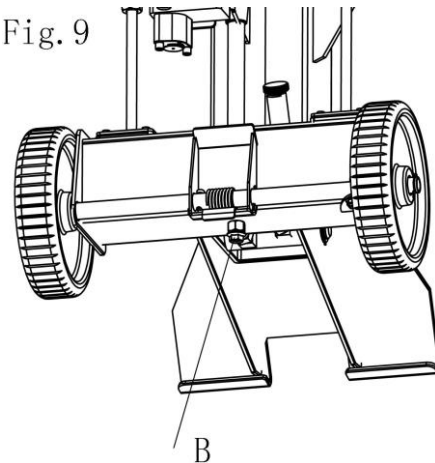

Fig. 9



### Checking the oil level

The hydraulic system is a closed system with oil tank, oil pump and control valve. Check the oil level regularly, before each use. Too low an oil level can damage the oil pump. The oil level must lie within the marks on the dipstick. The cleaver column must be retracted before checking the oil; the machine must be on a level surface.

When should I change the oil?

The first oil change should be carried out after 50 hours use, and then after every 500 hours use.

### Changing the oil - Fig. 9

Move the cleaver column in completely.

Place a container, with a capacity of at least 6 l, under the log splitter.

Loosen the vent cap A.

Open the drain plug B located under the oil tank to allow the oil to flow out.

Close the drain plug B again.

Pour in 4 liters of new hydraulic oil using a funnel.

Replace the vent cap.

Dispose of the waste oil properly at a local oil disposal point. The waste oil must not be poured into the ground or mixed with other waste.

We recommend the following hydraulic oils or equivalent:

Aral Vitam gf 22

BP Energol HLP-HM 22 Mobil DTE 11

Shell Tellus 22

Do not use any other types of oil!

The use of any other type of oil will adversely affect the operation of the hydraulic cylinder.

### Splitter blade

The splitter blade must be slightly lubricated before commissioning.

This procedure must be repeated after every 5 hours use. Lightly apply grease or spray oil.

The blade must not run dry.

### **Hydraulic system**

The hydraulic system is a closed system with oil tank, oil pump and control valve. Do not alter or tamper with the factory-installed system. Check the oil level regularly.

Too low an oil level will damage the oil pump.

Check the hydraulic and screw connections regularly for leaks – tighten them if necessary.

Clean the work area and keep the appropriate tools in good condition before starting any maintenance and inspection work.

The time intervals indicated here refer to normal use;

hence, if the machine is exposed to heavy loads, reduce these times accordingly.

Only clean the machine enclosures, the covers and control levers with a soft, dry cloth or dampen it slightly

With neutral detergent; do not use solvents, such as alcohol or gasoline, because they can damage the surfaces.

Keep oils and lubricants out of the reach of unauthorized personnel; read the instructions on the containers carefully and follow them without fail; avoid direct contact with skin and rinse well after use.

### **Accident prevention**

The machine must only be operated by qualified personnel, who are familiar with the contents of this manual.

Please check that the safety devices are whole and working correctly before using the machine. You should also familiarize yourself with the machine's control mechanisms, by reading the operating instructions.

The machine's stated performance must not be exceeded.

The machine must never be used for any purpose other than the one for which it is intended.

In accordance with the regulatory laws of the country, in which the machine is used, personnel must also wear working clothes as prescribed in that country; i.e. do not wear loose, fluttering clothes, belts, rings and necklaces; long hair should preferably be tied back. The work area should always be kept as neat and clean as possible, and tools, accessories and screw wrenches must always be within easy reach.

During cleaning and maintenance work, the machine must never be connected to the electric mains. Never operate the machine without the safety devices or with the safety mechanisms turned off. Never remove or modify the safety devices.

Do not carry out any maintenance or adjustment work before carefully reading this manual.

The periodical maintenance plan specified in this manual must be observed, both safety reasons and for the efficient operation of the machine.

Always keep the safety labels clean and legible and pay attention to them without fail to prevent accidents; if the safety labels are damaged or lost, or are among the parts, which have been replaced, they must be replaced with new, original labels, and be affixed to the specified position; you can obtain new labels from the manufacturer.

In the event of fires, only use powder fire extinguishers.

Do not extinguish fires in the machine with water; otherwise, there is a risk of a short circuit. If the fire cannot be extinguished immediately, pay attention to leaking liquids.

In the event of a longer fire, the oil tank or the lines, which are under pressure, can explode: therefore, make sure you do not come into contact with leaking liquids.

### **Dismounting and disposal**

The machine does not contain any harmful or polluting substances, as it is made of completely recyclable materials or of materials that can be disposed of in the normal way.

For disposal, contact specialist companies or qualified personnel who are well acquainted with the potential dangers and who have read and follow the present operating instructions strictly.

When the machine is no longer of use, proceed as follows, paying attention to all the accident prevention standards:

Disconnect the energy supply (electric or PTO).

Remove all power cables and take them to a specialized collection point, in accordance with the applicable provisions in the respective country.

Empty the oil tank; take the oil in sealed containers to a collection point, in accordance with the applicable provisions in the respective country.

Take all the machine's remaining parts to a scrap metal collection point, in accordance with the applicable provisions in the respective country.

Make sure that every machine part is disposed of in accordance with the applicable provisions in the respective country.



Electrical products should not be discarded with household products. According to the European Directive 2012/19/EU on waste electrical and electronic equipment and its implementation into national law, electrical products used must be collected separately and disposed of at collection points provided for this purpose. Talk with your local authorities or dealer for advice on recycling.



**EC Conformity declaration**

**BUILDER SAS**

ZI, 32 rue Aristide Bergès – 31270 Cugnaux - France  
Tel: +33 (0)5.34.502.502 Fax: +33 (0)5.34.502.503

We hereby declare that the machine described below due to its design and construction as well as the model marketed by us, complies with the relevant regulations of the EC directives listed below. In case of modifications to the machine, the present declaration loses its validity.

Designation of the machine: **ELECTRIC LOG SPLITTER**

Model: **HFBE8T55**

S/N: **20210734870-20210734965**

**20210736518-20210736613**

**Relevant EC directives:**

Machine Directive 2006/42/EC

EMC Directive 2014/30/EU

ROHS Directive 2011/65/EU and 2015/863/EU

**Applied harmonized European standards:**

EN60204-1:2006+A1:2009, EN609-1:2017

EN55014-1:2017, EN55014-2:2015, EN61000-3-2:2014, EN61000-2-11:2000

Cugnaux, 28/05/2021

Signature:

A handwritten signature in black ink, appearing to be 'Philippe Marie', written over a faint circular stamp or watermark.

Philippe MARIE / PDG

# HYUNDAI

## WARRANTY

The manufacturer guarantees the product against defects in material and workmanship for a period of 2 years from the date of the original purchase. The warranty only applies if the product is for household use. The warranty does not cover breakdowns due to normal wear and tear.

The manufacturer agrees to replace parts identified as defective by the designated distributor. The manufacturer does not accept responsibility for the replacement of the machine, in whole or in part, and/or ensuing damage.

### The warranty does not cover breakdowns due to:

- insufficient maintenance.
- abnormal assembly, adjustment or operations of the product.
- parts subject to normal wear and tear.

### The warranty does not extend to:

- shipping and packaging costs.
- using the tool for a purpose other than that for which it was designed.
- the use and maintenance of the machine done in a manner not described in the user manual.

Due to our policy of continuous product improvement, we reserve the right to alter or change specifications without notice. Consequently, the product may be different from the information contained therein, but a modification will be undertaken without notice if it is recognized as an improvement of the preceding characteristic.

### READ THE MANUAL CAREFULLY BEFORE USING THE MACHINE.

When ordering spare parts, please indicate the part number or code, you can find this in the spare parts list in this manual. Keep the purchase receipt; without it, the warranty is invalid. To help you with your product, we invite you to contact us by phone or via our website:

- **+33 (0)9.70.75.30.30**
- **<https://services.swap-europe.com/contact>**

You must create a "ticket" via the web platform.

- Register or create your account.
- Indicate the reference of the tool.
- Choose the subject of your request.
- Describe your problem.
- Attach these files: invoice or sales receipt, photo of the identification plate (serial number), photo of the part you need (for example: pins on the transformer plug which are broken).



# PRODUCT FAILURE

## WHAT TO DO IF MY MACHINE BREAKS DOWN?

### If you bought your product in a store:

- a) Empty the fuel tank.
- b) Make sure that your machine is complete with all accessories supplied, and clean! If this is not the case, the repairer will refuse the machine.

Go to the store with the complete machine and with the receipt or invoice.

### If you bought your product on a website:

- a) Empty the fuel tank.
- b) Make sure that your machine is complete with all accessories supplied, and clean! If this is not the case, the repairer will refuse the machine.
- c) Create a SWAP-Europe service ticket on the site: <https://services.swap-europe.com> When making the request on SWAP-Europe, you must attach the invoice and the photo of the nameplate (serial number).
- d) Contact the repair station to make sure it is available before dropping off the machine.

Go to the repair station with the complete machine packed, accompanied by the purchase invoice and the station support sheet downloadable after the service request is completed on the SWAP-Europe site

For machines with engine failure from manufacturers BRIGGS & STRATTON, HONDA and RATO, please refer to the following instructions.

Repairs will be done by approved engine manufacturers of these manufacturers, see their site:

- <http://www.briggsandstratton.com/eu/fr>
- <http://www.honda-engines-eu.com/fr/service-network-page;jsessionid=5EE8456CF39CD572AA2AEEDFD290CDAE>
- <https://www.rato-europe.com/it/service-network>

**Please keep your original packaging to allow for after-sales service returns or pack your machine with a similar cardboard box of the same dimensions.**

**For any question concerning our after-sales service you can make a request on our website <https://services.swap-europe.com>**

**Our hotline remains available at +33 (9) 70 75 30 30.**



# WARRANTY EXCLUSIONS

## THE WARRANTY DOES NOT COVER:

- Start-up and setting up of the product.
- Damage resulting from normal wear and tear of the product.
- Damage resulting from improper use of the product.
- Damage resulting from assembly or start-up not in accordance with the user manual.
- Breakdowns related to carburetion beyond 90 days and fouling of carburetors.
- Periodic and standard maintenance events.
- Actions of modification and dismantling that directly void the warranty.
- Products whose original authentication marking (brand, serial number) has been degraded, altered or withdrawn.
- Replacement of consumables.
- The use of non-original parts.
- Breakage of parts following impacts or projections.
- Accessories breakdowns.
- Defects and their consequences linked to any external cause.
- Loss of components and loss due to insufficient screwing.
- Cutting components and any damage related to the loosening of parts.
- Overload or overheating.
- Poor power supply quality: faulty voltage, voltage error, etc.
- Damages resulting from the deprivation of enjoyment of the product during the time necessary for repairs and more generally the costs related to the immobilization of the product.
- The costs of a second opinion established by a third party following an estimate by a SWAP-Europe repair station
- The use of a product which would show a defect or a breakage which was not the subject of an immediate report and/or repair with the services of SWAP-Europe.
- Deterioration linked to transport and storage\*.
- Launchers beyond 90 days.
- Oil, petrol, grease.
- Damages related to the use of non-compliant fuels or lubricants.

\* In accordance with transport legislation, damage related to transport must be declared to carriers within 48 hours maximum after observation by registered letter with acknowledgement of receipt.

This document is a supplement to your notice, a non-exhaustive list.

**Attention:** all orders must be checked in the presence of the delivery person. In case of refusal by the delivery person, it you must simply refuse the delivery and notify your refusal.

**Reminder:** the reserves do not exclude the notification by registered letter with acknowledgement within 72 hours.

### Information:

Thermal devices must be wintered each season (service available on the SWAP-Europe site). Batteries must be charged before being stored.



**HYUNDAI**  
POWER PRODUCTS

**For Inquiries, please contact:**

BUILDER SAS  
32, Rue Aristide Bergès Z1 31270 Cugnaux, France  
Tél.: +33(0)5.34.502.502 Fax : +33(0)5.34.502.503  
<http://www.hyundaipower-fr.com/>  
Fabriqué en République Populaire de Chine(PRC)